

ASPHALT CONTINUOUS PLANTS PREMIUM

# ACP CONTIMIX 2.0

INNOVATIVE AND  
MULTI-PURPOSE  
CONTINUOUS  
ASPHALT PLANT



**READY FOR TODAY AND TOMORROW**  
EASY UPDATES THROUGH SMART DESIGN

**AMMANN**

The Contimix 2.0 combines the advantages of both worlds: batch and continuous. Winning features include high production output, recipe flexibility a low investment cost.

Thanks to the twin-shaft continuous mixer, the contimix produces a high homogeneity, consistent mix. The heat-sensitive bitumen can be added to the mixed material outside of the dryer.

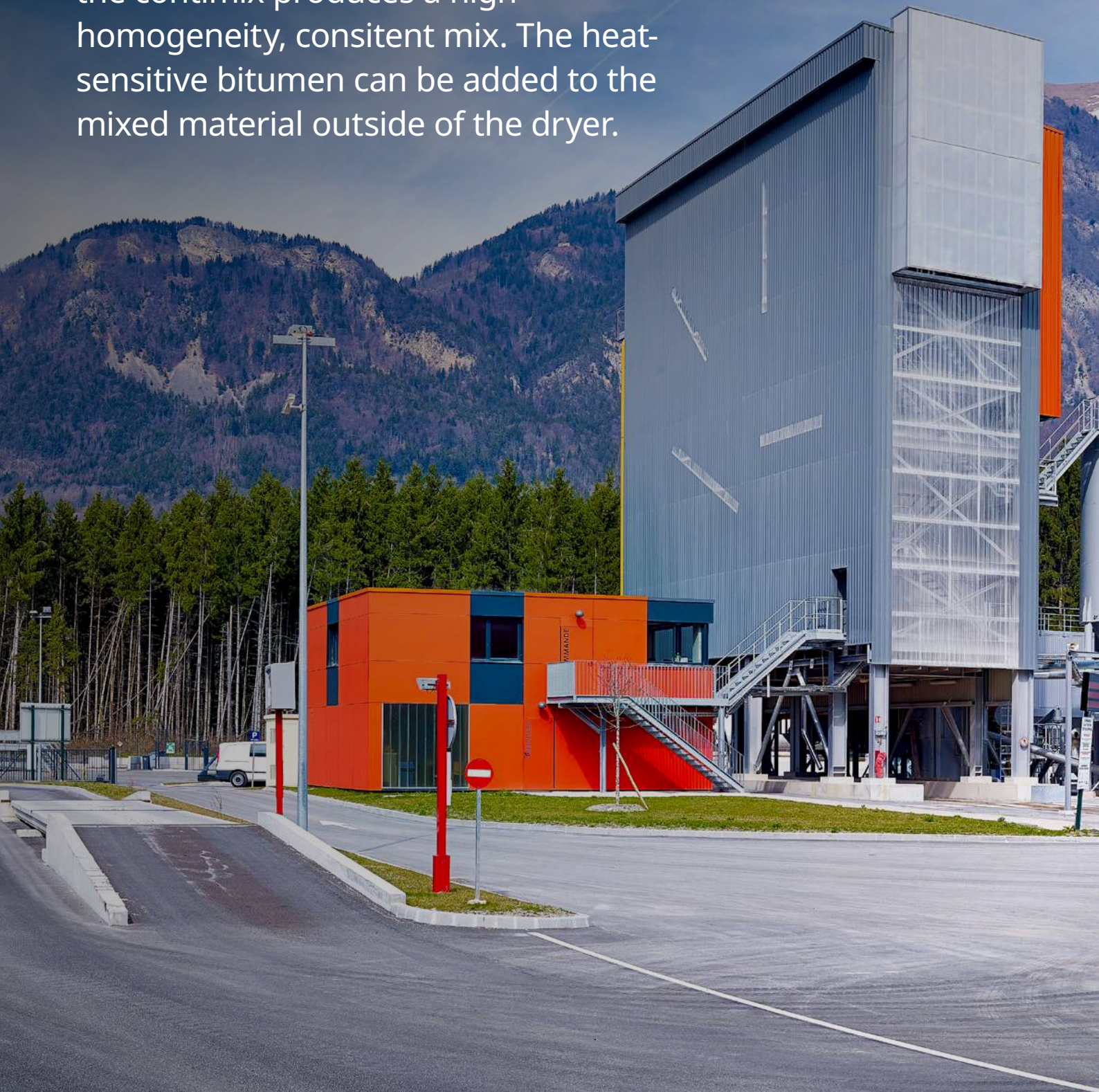



## INDEX

- 4 AMMANN CONTINUOUS PORTFOLIO
- 6 FEATURES
- 8 ADVANTAGES OVERVIEW
- 10 QUALITY & RELIABILITY
- 12 LOW ENVIRONMENTAL IMPACT
- 16 EFFICIENCY & ENERGY SAVINGS
- 20 SUSTAINABLE SOLUTIONS
- 23 AS1 CONTROL SYSTEM
- 24 TRANSPORT & INSTALLATION
- 26 AMMANN AFTER SALES FOR PLANTS
- 30 AMMANN GLOBAL PRESENCE

# AMMANN CONTINUOUS PORTFOLIO

Consistent from start to finish.

All plant processes and components are carefully developed to ensure that feeding, heating, drying, screening and mixing seamlessly blend together. Helping integrate all the moving parts is the as1 Control System, which provides leading technology with a user-friendly interface.

## Some things never change

Ammann has had a presence in road construction equipment for over 150 years, collecting experiences and know-how and developing the technologies of the future.

What hasn't changed is how Ammann does business. To this day all core components are engineered and

manufactured in-house to create a perfect fit and ultimately provide quality, efficiency and long life. This approach also means a single point of contact for virtually all plant needs.

A century of industry expertise, meanwhile, ensures an understanding of your business and the development of plants that provide real-world solutions.

## CONTINUOUS PORTFOLIO

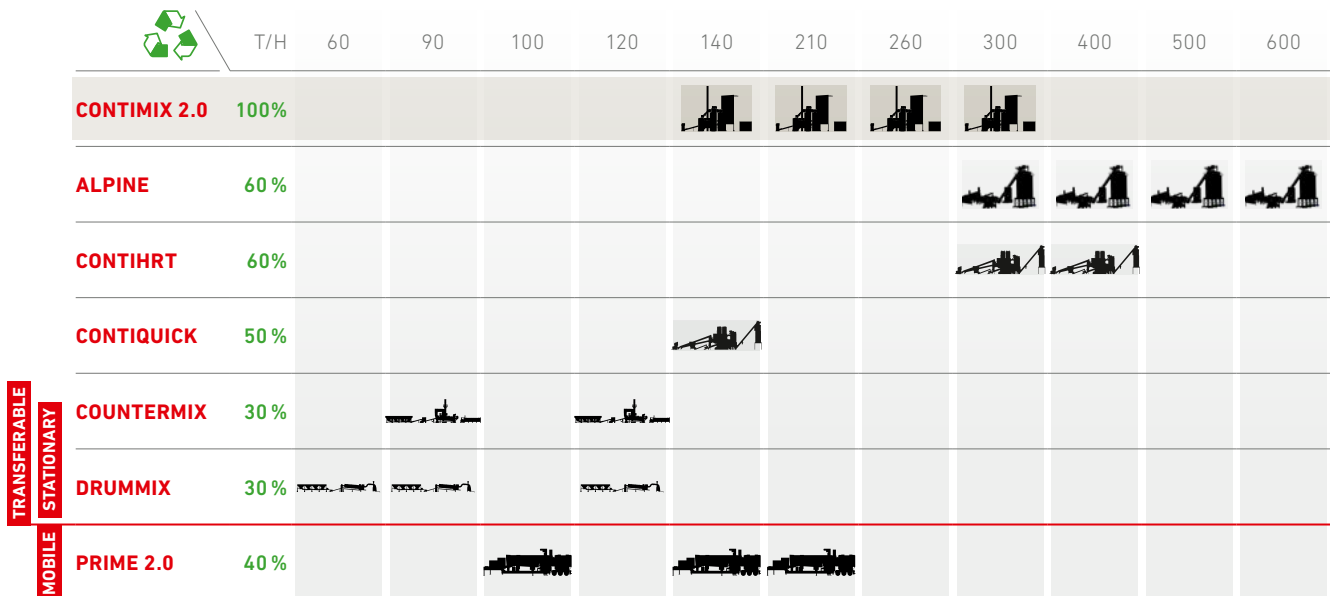

# AMMANN CONTIMIX 2.0 PLANT PERFORMANCE

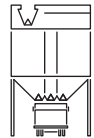
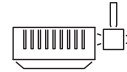
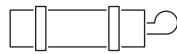

TYPE	Plant Asphalt Max. Production [t/h]		Dryer Drum Type	Burner [MW]	Filter		Mixer Type Capacity Asp. Prod. [t/h]	Ready Mix Silo
	3%	5%			Type [Surface m <sup>2</sup> ]	Fan Vol. [Nm <sup>3</sup> /h]		
140	140	110	RAH 50 2080	10	AFA 2445 [333]	28.000	Amix 1.125 ACR [35-140]	Direct loading; From 30 up to 500 t in 1 loading line; Up to 300 t in 3 loading lines; Load cells available; Medium or long-term storage solution available.
210	210	170	RAH 50 2390	14	AFA 3042 [483]	37.000	Amix 1.20 ACR [55-210]	
260	260	210	RAH 50 25100	18	AFA 3062 [724]	57.000	AMIX 2.40 ACR [85-340]	
300	300	240	RAH 50 27110	20	AFA 3069 [804]	63.000		

Recommended configuration; Please contact Ammann Sales Force for tuning your asphalt plant.



# ZERO-WASTE, FLEXIBLE AND HIGHLY CUSTOMIZABLE SOLUTION

Ammann contimix 2.0 plants set the standard for mix production in the 140 to 300 ton per hour output classes.

- Separating the processes enables adjustment of mixing times;
- Providing flexibility and significantly reducing emissions;
- Plant operators also appreciate the ability to easily modify recipes without stopping and starting, a nice cost saver;
- Amazing uniformity of each batch due to a unique material mixing;
- Twin-shaft paddle mixer delivers maximum shear forces;
- Optimum homogeneity and mixing times;
- Maximum flexibility in the sequence enables the production of special mixtures;
- In the event of power interruptions, the mixer can be discharged immediately with an emergency discharge flap.



▄▄ THE SMARTEST,  
GREEN AND  
FLEXIBLE  
CONTINUOUS  
PROCESS. ▄▄



# CONTINUOUS MIXING PLANTS: ADVANTAGE OVER ALL OTHERS

Exceptional performance, reliability and quality are the cornerstones of our customer commitment. These criteria create unique advantages that separate the Contimix 2.0 from competitors' plants.

We continuously invest in technology and innovation to ensure the best solutions for efficiency, energy savings and sustainability. The utilisation of recycled asphalt lessens the plant's environmental impact while offering scalable solutions for specific needs.

Optimised transport and on-site assembly bring flexibility, cost-effectiveness and immediate production to our customers.

Last, but certainly not least, is the highly advanced as1 Control System that furthers production efforts.



## SUSTAINABLE SOLUTIONS

- Four different levels of RAP technologies: RAC, RAH50 2<sup>nd</sup> Gen., RAH60, RAH100;
- Designed to produce **cold, warm,** and **hot** mix asphalt.



## EFFICIENCY & ENERGY SAVING

- Ammann technology provides efficient energy consumption compared to competitive plants;
- Low energy consumption = low CO<sub>2</sub> emissions;
- Low energy consumption = reduced operating costs.



## TRANSPORT & INSTALLATION

- **Best TCO plant** on the market:
- Super-Transferable plant: can be equipped with steel basis = no concrete foundations;
- Available with Plug & Play electrical connection for quick assembly or relocation.





Continuous  
asphalt mixing



## LOW ENVIRONMENTAL IMPACT

- No loss of material during start-up and shut down because of “zero waste” system;
- Available with scalable solutions for air and sound emissions.



## QUALITY & RELIABILITY

- Ammann provides excellent value in dryers and burners, filter bags, screens and mixers, and control system;
- All core parts are developed in Switzerland;
- Special solutions such as Amdurit and Ammatex solve real customer problems.



## AS1 CONTROL SYSTEM

- At work in more than 3000 plants globally;
- Most innovative and complete system ever designed for asphalt plants.



## QUALITY & RELIABILITY



Ammann asphalt-mixing plants utilise complex process engineering that requires perfect interaction between all individual components.

So essential is this integration that Ammann engineers all core components in-house - including drums, burners, filters, screens, controls and mixers.

Doing so is the only way to guarantee that our plants will meet the demanding requirements and standards of the modern market environment. Ammann is currently the only manufacturer of asphalt-mixing plants to offer this single-source approach, establishing us as a professional partner to handle every aspect of your asphalt-mixing plant. We provide answers when you need them and keep an open mind in order to fully understand your needs.

# AMMANN



## DRYER DRUM

- A single manufacturer provides all drying / heating / exhaust management processes, ensuring perfect attunement;
- A wide range of dryer sizes for plant capacities of 140 to 300 tonnes per hour to meet varied needs;
- Optimised heat transfer stages and dryer insulation for maximum efficiency and fuel savings;
- Low-wear, low-maintenance design with high material quality and easy exchange of wear parts;
- Adaptable internal dryer design for use of varied aggregates and fuels.



## BURNER

- Multi-fuel firing with simultaneous or alternating combustion of up to three fuel types for maximum flexibility;
  - A highly effective combustion process for low fuel consumption and emissions;
  - Combustion of solid pulverised fuel without the need of a supporting flame;
  - Integrated soundproofing for reduced sound; further reduction possible through a frequency converter;
  - Safety concept meets regulations of all countries.
- Available for varied liquid, gas and solid fuels:
    - Light oil
    - Heavy oil
    - Waste oil
    - Bio oil
    - Kerosene
    - LPG
    - Natural gas
    - LPG in a gas state
    - Coal dust
    - Wood dust



## FILTER

- Proprietary rotor step mechanisms gently clean the filter bags;
- Filtration efficiency of 99.9% ensures compliance;
- The largest possible surface provides optimal filtration efficiency;
- Minimal moving parts reduce maintenance and improve reliability;
- High-quality aluminium supporting cages are acid resistant;
- The CFD-supported baghouse design reduces temperature and pressure losses.



## SCREEN

- Precisely controlled variables include stroke angle, amplitude, frequency, screen body design and mesh geometry. The result is the highest-performing screens in the market;
- Optimised for high temperatures;
- The screen is state-of-the-art;
- Easy integration due to identical interfaces.

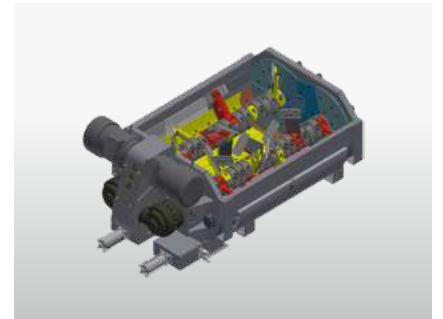

## MIXER

- Minimal wear through protected components and an efficient mixing process;
- Compulsory twin-shaft mixer provides highest shear forces;
- Optimal homogeneity and mixing time through the unique Ammann paddle arrangement;
- Maximum sequence design flexibility that enables production of special mixes.



# LOW ENVIRONMENTAL IMPACT

A shortage of industrial land means that asphalt-mixing plants must increasingly be located closer to residential areas.

That makes it more important than ever that plants minimise noise in an effort to be good neighbours and to meet local requirements.

- Ammann offers four levels of noise suppression;
- Ammann plants are designed for easy cladding;
- Cladding prevents dust and fumes from being released in the atmosphere;
- Cladded plants are aesthetically pleasing—an essential factor when seeking approvals in urban areas.



## Air and sound emission control

Specific solutions are designed to confine and manage the exhaust emissions out of the storage silos. These blue smoke fumes are collected and conveyed into a dedicated filter designed to clean the air from the aerosol of oils contained.

- ACP Contimix 2.0 plants are designed for easy positioning of cladding;
- From an environmental point of view, no dust spillage and fumes are released into the atmosphere;
- Urbanistic aspects can be satisfied with complete uniform cladding according to construction permission.







# LOW ENVIRONMENTAL IMPACT

Bitumen fumes are the primary source of odour. Ammann offers different solutions to reduce the fumes – and the odour that can result.





### Blue Smoke Treatment

The system, developed by Ammann, addresses the blue smoke that is released during truck loading.

With this process, the vapours are aspirated at the skip or diverted under the mixer – not near the discharge doors of the finished product silo.

The system is based on the principle that hot air rises, thus decreasing the volume above the finished product silo. At this point in the process, blue smoke is piped to a cooling system for the condensation of the oily phase – and subsequently to an oil separator for the capture of the finest oily particles.

The treated gases are transferred to the burner and ignited.

### Odour Neutralization System

The system attacks odour emissions at two key points.

1. A special kit inserted in the chimney neutralizes emissions generated during production;
2. In addition, a mist barrier blocks odours in the load-out area.



## EFFICIENCY & ENERGY SAVING

Ammann plants enable customers to carry out their duties efficiently and productively. The plants help customers work smarter, not harder.



### Filter

- Less pressure lost means lower energy consumption;
- The new design ensures uniform distribution of exhaust air inside the filter;
- Proper distribution/filling utilises more of the bag surface and improves efficiency.



Our sustainable promise

## Burner

- New technology controls the flame shape;
- More power can be given in smaller dryers, resulting in efficiency and energy savings per ton of aggregates dried and heated;
- A special software optimises air/fuel mixing for increased combustion efficacy, leading to significant annual savings in fuel.

## Dryer

- Contimix 2.0 dryers are highly efficient at production levels of up to 64 t/h (at 3% moisture content) per square metre – 22% more efficient than the existing standard.
- This results in low energy consumption, which in turn reduces fuel costs and CO<sub>2</sub> emissions.
- The heating exchange efficiency in the dryers facilitates fume temperatures that are normally between 85°C to 90°C.
- That temperature range is 20°C less than competitive dryer drums and can be measured in savings of 1 kWh/T.

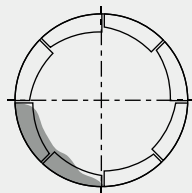

CONVEYING

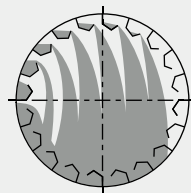

CONVECTION

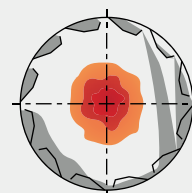

RADIATION

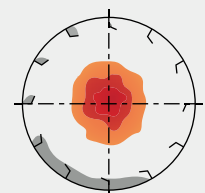

DISCHARGE



## EFFICIENCY & ENERGY SAVING



### AMMANN FOAM

Ammann believes low temperature asphalt mixes are the future of the asphalt industry. Therefore, we developed the Ammann Foam System in collaboration with our customers and internal experts.

The low temperatures associated with the use of Ammann Foam provide big advantages:

- Higher workability during mix production and placement;
- Improved compaction performance;
- Extension of the paving season;
- An ability to deliver mixes longer distances;
- Better recycling performance.

Using Ammann Foam to produce warm mix asphalt (WMA) provides additional benefits:

- Reduced VOC emissions from bitumen;
- Lower levels of gas emissions and CO<sub>2</sub> from savings in drying and heating of virgin aggregates;
- Diminished fumes, emissions and odours;
- Quicker opening of roads to traffic;
- Savings in production costs through reduced energy consumption.

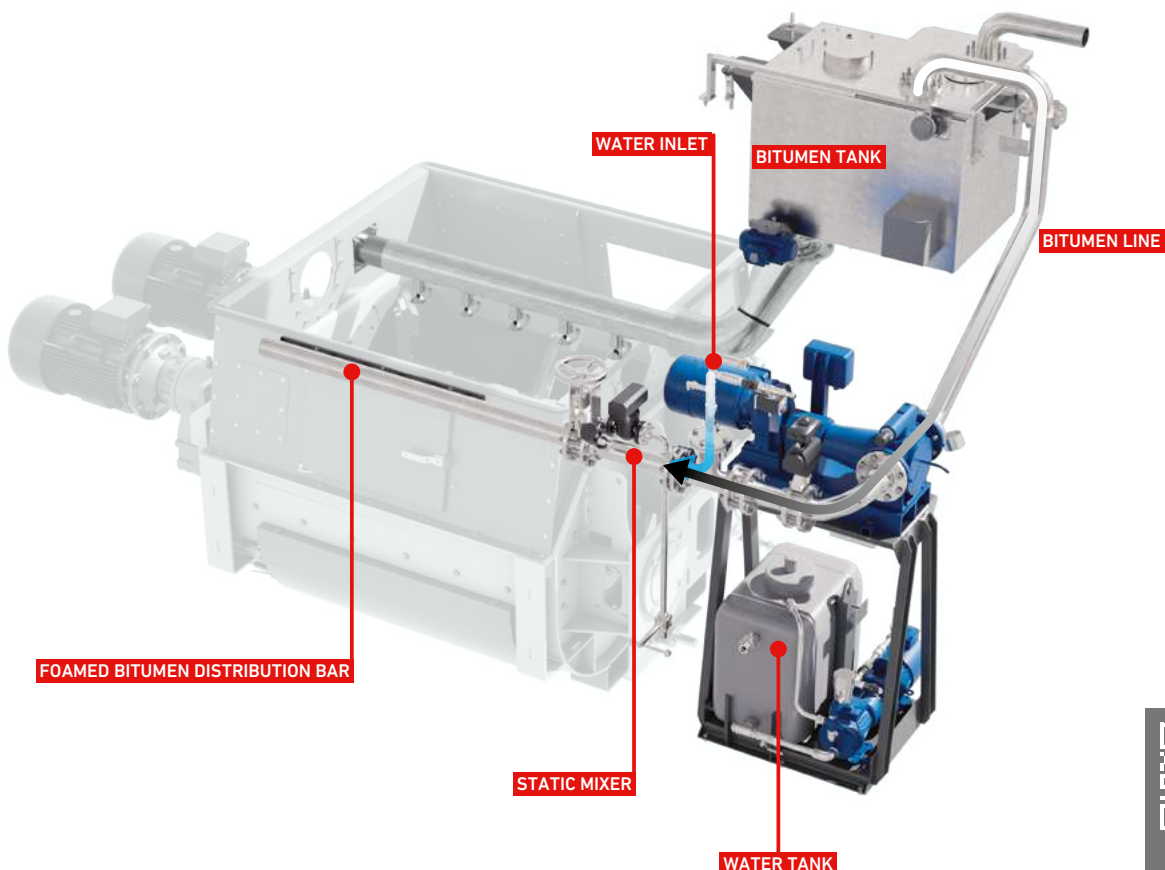

## AS1 ECOVIEW

This as1 module helps uncover and eliminate energy waste.

An intuitive display informs operators and enables immediate adjustment. This gives operators the data they need to make decisions around throughput and material control to maximize savings and efficiencies

EcoView also determines the values of emitted CO<sub>2</sub> and calculates energy costs that result when adjustments are made, and operations become more efficient.

### HIGHLIGHTS

- Intuitive operator display showing how efficient the plant runs;
- Displays key values and enables comparison to reference values and previous periods;
- Determines the emitted CO<sub>2</sub> values;
- Determines the resulting energy costs.

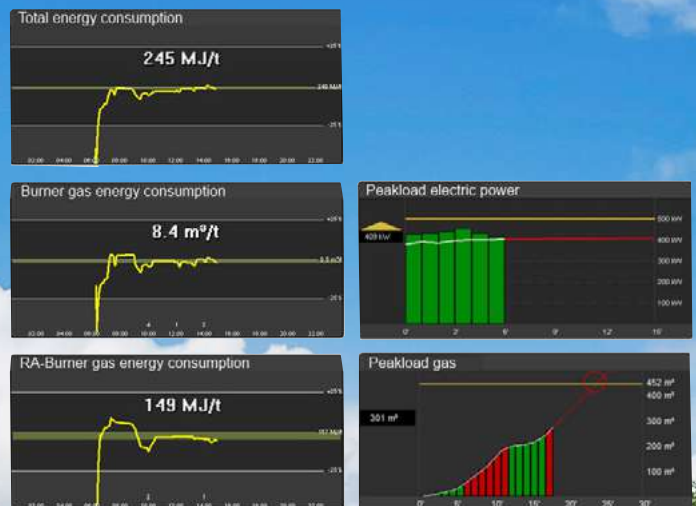



# SUSTAINABLE SOLUTIONS

The use of recycled asphalt is a necessity given today's sustainability needs. Ammann is a world leader in the development of RAP technology.

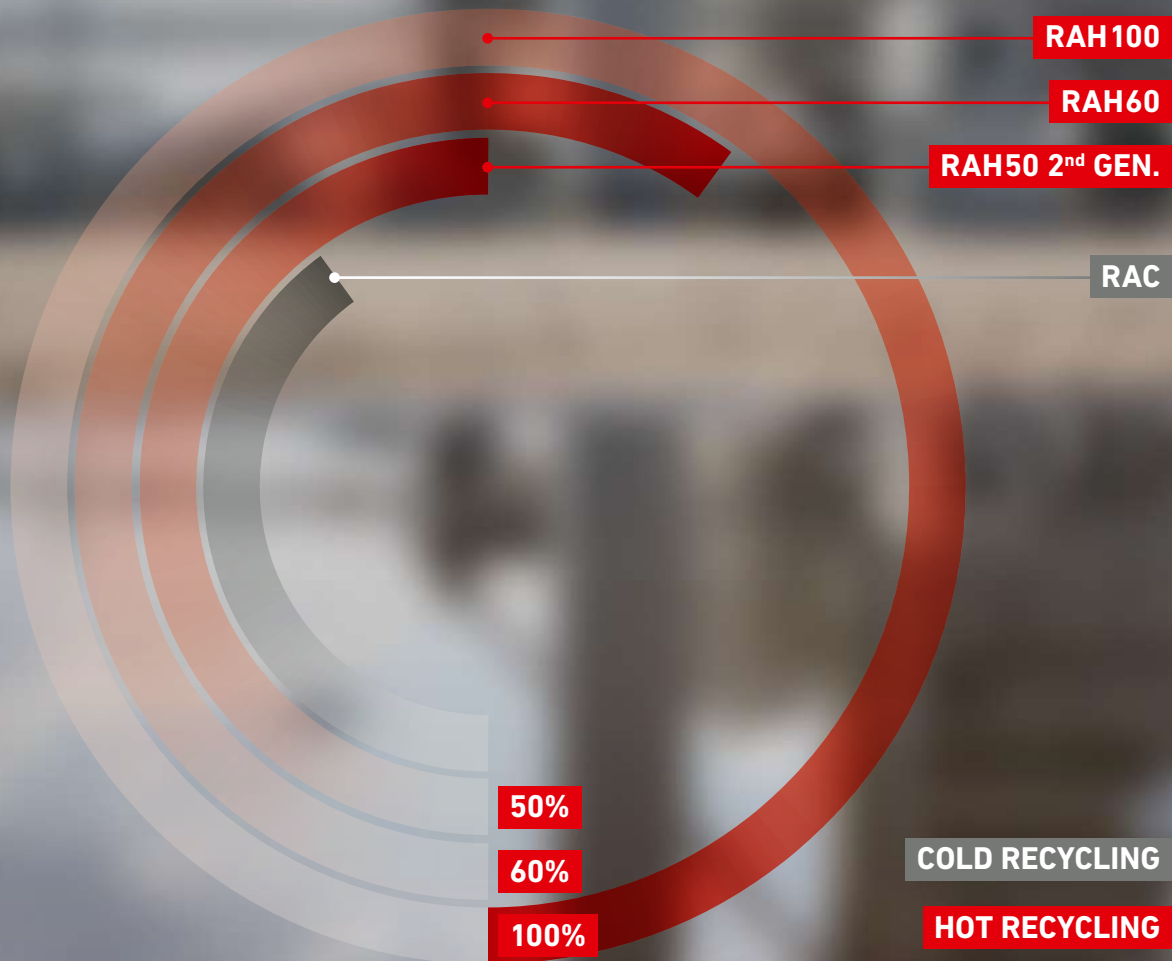

**UP TO 30% COLD FEED  
INTO THE MIXER**



**BENEFITS**

- Allows 100% cold production, i.e. complete bypass of the dryer;
- Allows the best work with warm mixes;
- Allows integration of the most delicate and fine recycled material, reducing any sticking along the hot line;
- Allows high flexibility in recipe changes;
- It's the best solution when combined with the RAH 50 2<sup>nd</sup> Gen.

**UP TO 50% HOT FEED  
RAH 50 2<sup>nd</sup> GEN.**



**BENEFITS**

- Processes RAP proportions of up to 50%;
- Optimal investment/performance ratio;
- Energy savings through efficient processing of new material;
- Lower emissions, thanks to gentle heating of RAP;
- Advanced technology – as proven by Ammann's industry leadership and three international patents.

**UP TO 60% HOT FEED  
IN PARALLEL DRUM RAH60**



**BENEFITS**

- New minerals can be screened;
- High feed ratio;
- Gentle heating;
- Combinable with cold feed system.

**100% HOT FEED  
IN RECYCLING DRUM RAH100**



**BENEFITS**

- Recycling rates of up to 100% are achievable;
- Lowest-emission solution: meets the strictest regulations;
- Improved process and efficiency: cost benefits through fuel savings and correct reuse of RAP;
- Recipes are more flexible as there is no need to overheat the minerals.

## as1 Peak Load Management

Energy suppliers typically base pricing on usage or capacity. For the latter, the measured peak sets the price. Therefore, it is in the best interest of plant owners/operators to keep usage as low as possible during peak loads.

The as1 Peak Load Management module continuously monitors peak usage against critical values. It predicts peak times and reduces load during the costliest periods.

Some plant devices can be switched off during these periods. The module also utilises automatic stepping based on forecasts.

Peak Load Management works seamlessly with the as1 EcoView module and is available for both electricity and gas.

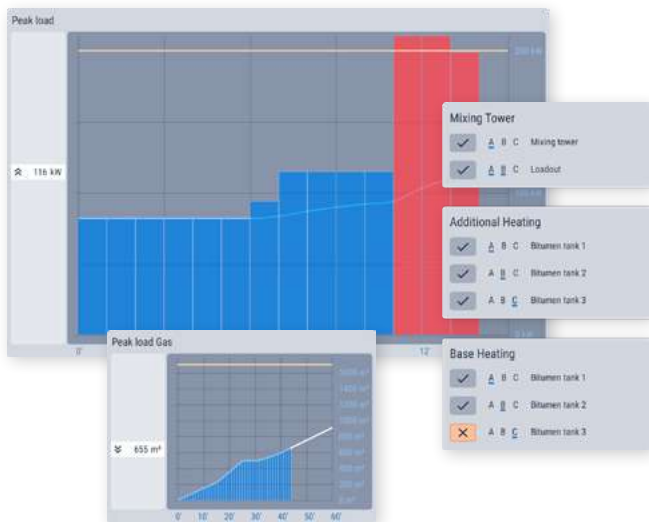

### HIGHLIGHTS

- Prevents short-term, expensive usage during peak loads;
- Forecast function;
- Automatic switch off for electrical consumers.

## as1 Dynamic Recycling Addition

The RAD module makes it easy to modify the RAP ratio. An integrated wizard guides the operator through the recipe input process. Slide controls enable adjustment of the RAP ratio during production.

It is designed to ensure that RAP addition, and therefore binder saving, are always maximized: This gives operators the confidence to keep throughput high while maintaining quality as the overarching priority. This, in turn, ensures that efficiency is excellent and therefore profitability is maximized.

### Various RAP ratios in a single recipe

Use of reclaimed asphalt protects natural resources and also offers economical advantages. The optional as1 module “dynamic RAP addition” makes it easy to modify the RAP ratio in accordance with requirements, even during production.

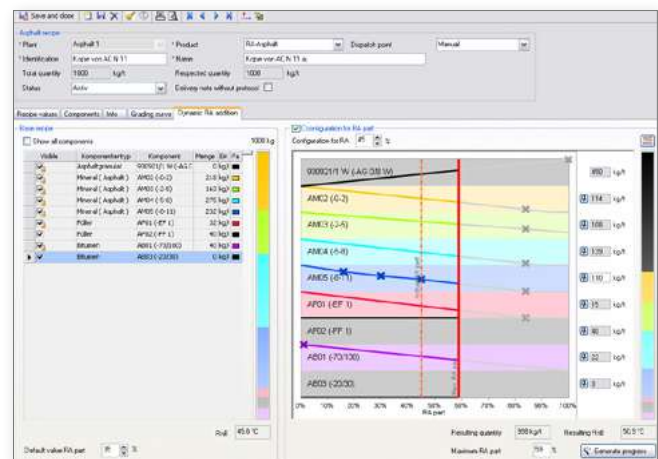

### HIGHLIGHTS

- The integrated wizard guides operator through the recipe input process;
- One recipe is sufficient for numerous RAP ratios;
- Change the RAP ratio by using the slide controls during production.

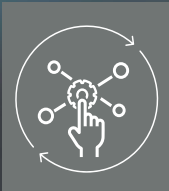

# AS1 CONTROL SYSTEM

The powerful and future-oriented as1 system concept combines proven Ammann software with specially matched industrial hardware.

The as1 computing environment has been designed and tested for use in tough environments. Its networking capability also has been optimised. Customers profit from the flexible workstation configuration, networking and administration.

## THE FIELD BUS SYSTEM

Guaranteed for reliable signal transfer

The proven field bus system is robust and reliable under tough operation. Faults can be detected efficiently and rectified by means of the diagnostic tools, even via remote support.

## THE POWER CABINET'S COMPONENTS

Designed for tough, round-the-clock operation

The power cabinet's components have to withstand extreme stress 24 hours a day, which is why Ammann only uses tried-and-tested, globally available quality components from renowned manufacturers.

## HOTLINE AND SUPPORT

Plant availability assured

Electromechanical faults can be quickly resolved by the customer's own personnel with the help of the electrical circuit diagrams and the as1 diagnostic tools.

Ammann's knowledgeable customer service team staffs the hotline, which can be called for fault diagnosis or maintenance at any time. Modern telecommunications media increase the availability of the plant and reduce the need for costly on-site servicing.

## HIGHLIGHTS

- Comprehensive system functionality;
- Quick and easy to learn;
- Safe to operate;
- Proven, reliable field bus and load-sharing;
- Professional hotline and support organisations ready for service worldwide.





# TRANSPORT & INSTALLATION

Ammann plants are designed and engineered to simplify transport and on-site assembly.

Cost-effective transport and erection are essential to customer value. Plant options include steel bases that enable installation on stabilised soil – without the need of a concrete foundation. All cables are pre-assembled and tested in house.



# QUICK INSTALLATION

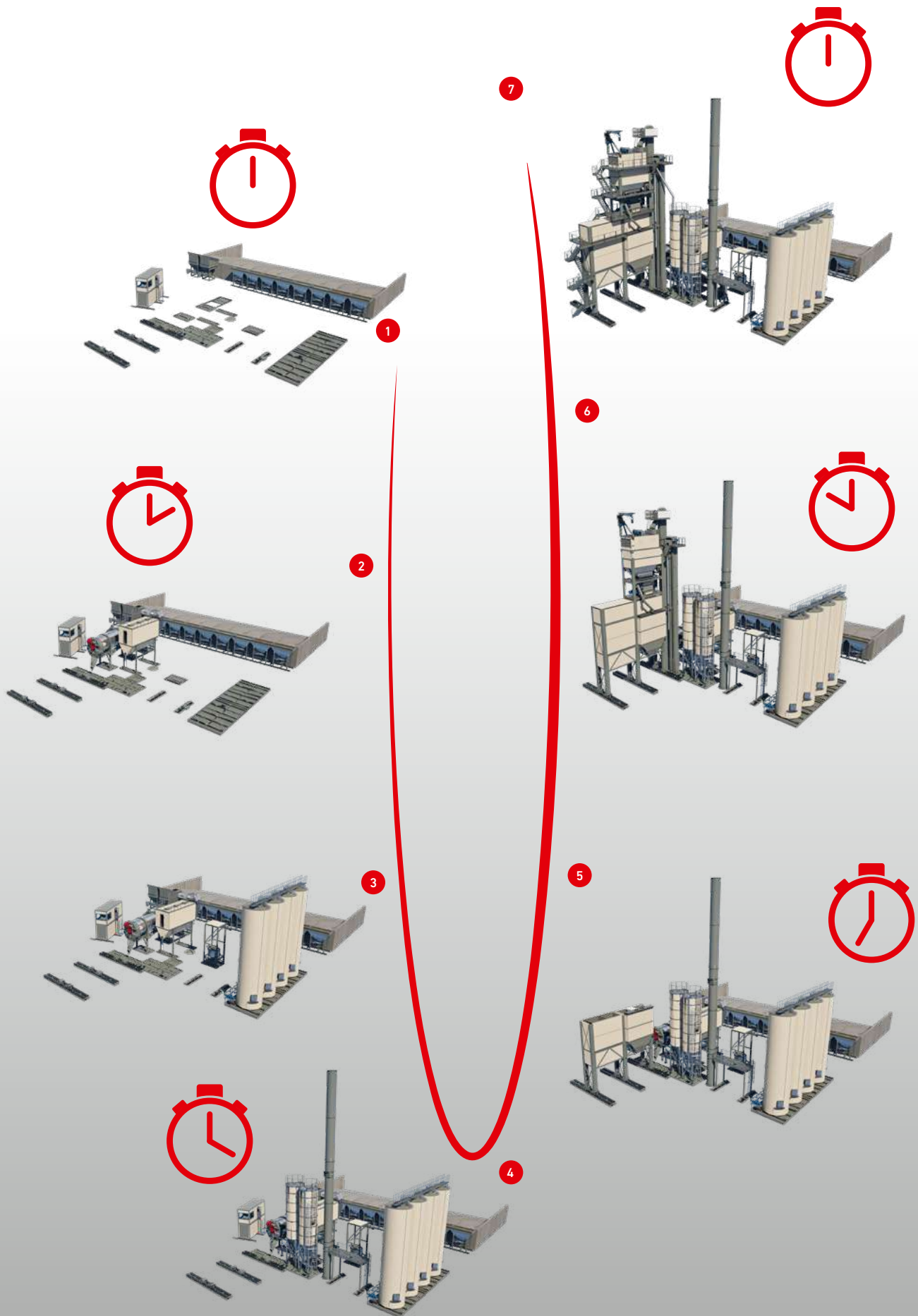

# AMMANN AFTER SALES FOR PLANTS

Contracted maintenance services and technician training provided by Ammann help protect your investment, while operator training ensures your team is able to utilise all the features and benefits built into your plant. When your needs change, Ammann offers retrofit options that can provide you with a good-as-new plant at a low cost.

## Retrofitting

- Improve the technological level of the plant;
- Increase component life;
- Increase the plant's efficiency.

## Original Spare Parts

- Maintain the initial performance of the plant;
- Maximise plant use times (no stops in production);
- Monitor the maintenance costs.



### Training

- Increase the plant's efficiency;
- Reduce unnecessary costs;
- Maximise plant use time.

### Technical Service

- Assembly and professional testing of the system;
- Technical assistance;
- Preventative maintenance.

# AMDURIT

Amdurit, Ammann's proprietary wear-protection system, provides up to three times the service life of wear-resistant steel and protects valuable parts and components.

## BENEFITS

- Three times more durable than wear-resistant steel;
- Lower operating costs;
- Longer lifetime;
- Fast installation;
- Reduced downtime.



# AUTOMATED LUBE SYSTEM

What if a single procedure could extend the life of your plant, reduce fuel costs and improve safety, too?



## BENEFITS

- The Ammlub system is directly mounted on the lubrication point and guarantees continuous relubrication at short intervals;
- Lubricants can be replaced while the plants are running, optimising routine maintenance while keeping your plant productive;
- Improves safety by removing workers from the process;
- Reduces energy costs up to 10%.

# AMMATEX FILTER BAGS

Multiple filter bag types are available to ensure you have a perfect fit at your plant.

## BENEFITS

- Precise manufacturing ensures quick installation and a perfect fit;
- Suitable for all fuel types;
- Exceptional price/performance ratio;
- Low emission values thanks to proper sealing and fitting;
- Reduced plant operating costs due to extended life of bags.



# AMMANN'S GLOBAL PRESENCE

## An Innovative, Sustainable Business

Ammann is a world-leading supplier of mixing plants, machines and services to the construction industry, with core expertise in road-building and transportation infrastructure. We are committed to sustainability – in both the products we make and the ways we make them.

Our strengths are the forthcoming approach of a family firm that has been operating for many years, coupled with our strong and well-established international presence. Since 1869, we have been setting benchmarks in the road-building industry, thanks to countless innovations and solutions that are as competitive as they are dependable.

True to our motto, "Productivity Partnership for a Lifetime," we gear our activities to the needs and requirements of our customers around the globe. Plants and machines that consistently prove their merits under demanding conditions are the best way to give our customers the critical, competitive edge they need.

Our reliable, punctual service network provides the essential spare parts that keep our customers working – and supports the plants and machines throughout their lifetimes.

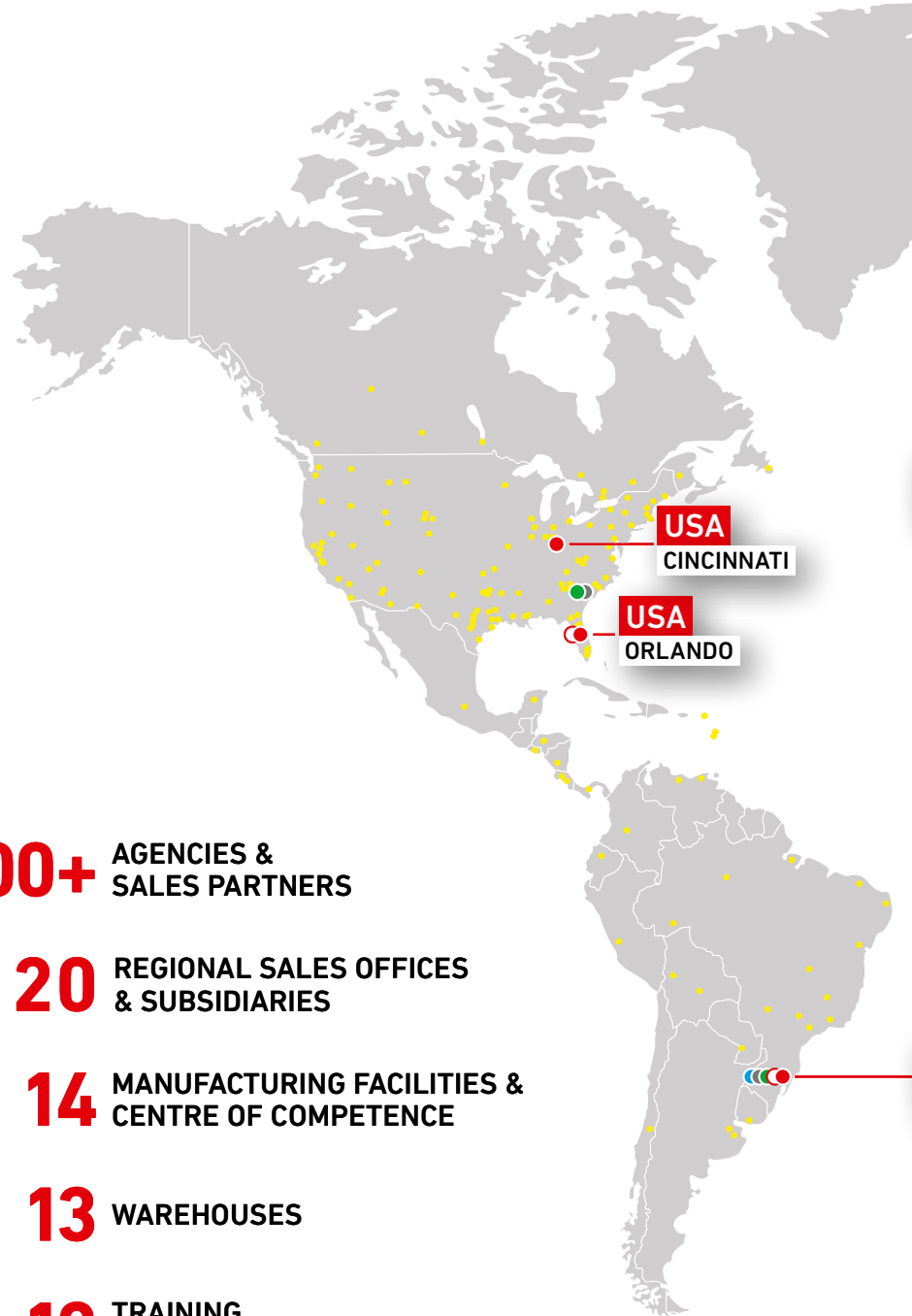

**200+** AGENCIES & SALES PARTNERS

**20** REGIONAL SALES OFFICES & SUBSIDIARIES

**14** MANUFACTURING FACILITIES & CENTRE OF COMPETENCE

**13** WAREHOUSES

**12** TRAINING CENTRES



### PLANTS

ASPHALT-MIXING PLANTS

CONCRETE-MIXING PLANTS

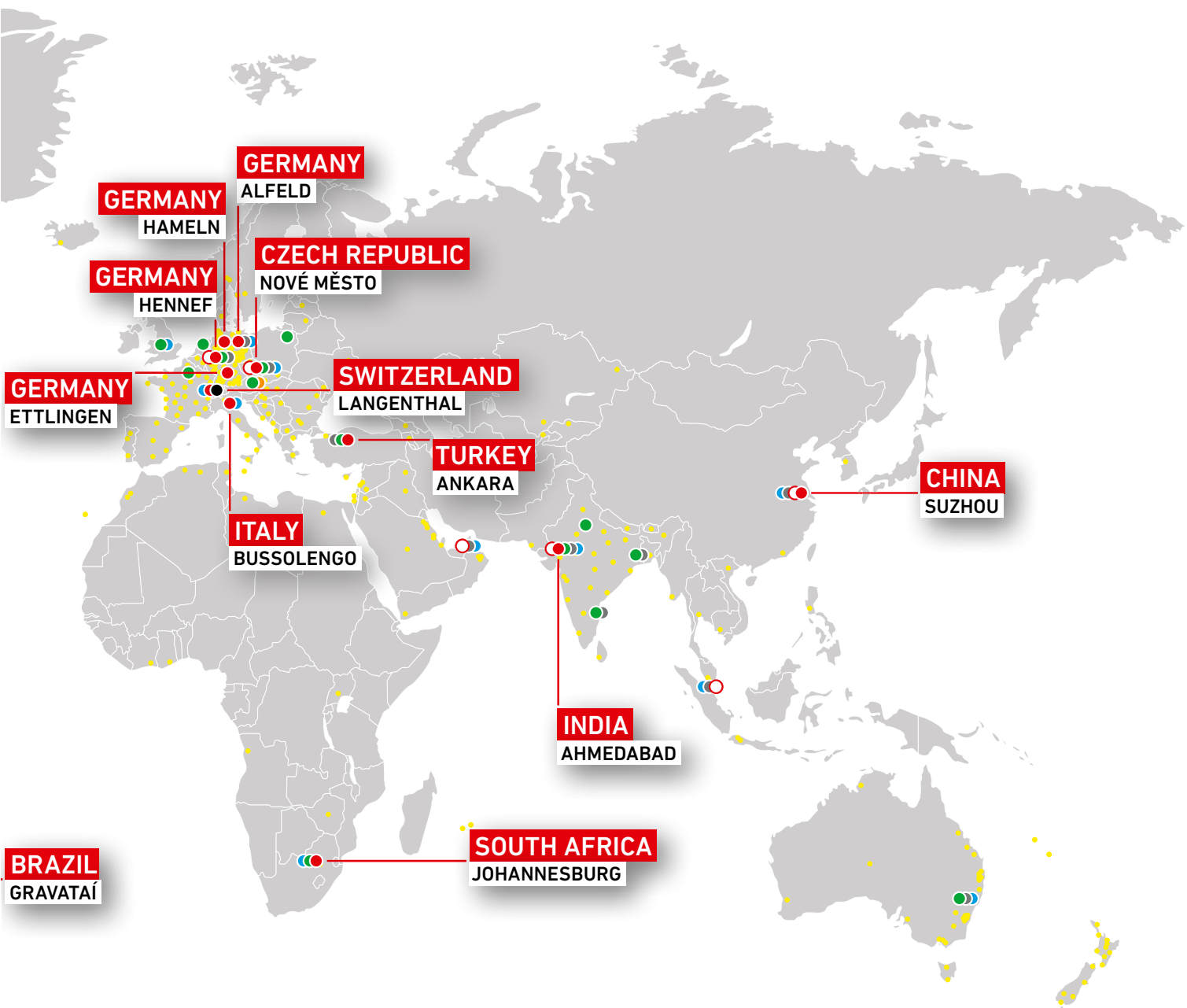

**GLOBAL DISTRIBUTION & SERVICE NETWORK**

- HEADQUARTERS
- REGIONAL SALES OFFICES
- SUBSIDIARIES
- AGENCIES & SALES PARTNERS
- MANUFACTURING FACILITIES & CENTRE OF COMPETENCE
- GLOBAL RETROFIT CENTRE
- WAREHOUSES
- TRAINING CENTRES



**MACHINES**

- LIGHT COMPACTION
- SOIL & ASPHALT COMPACTION
- ASPHALT PAVERS

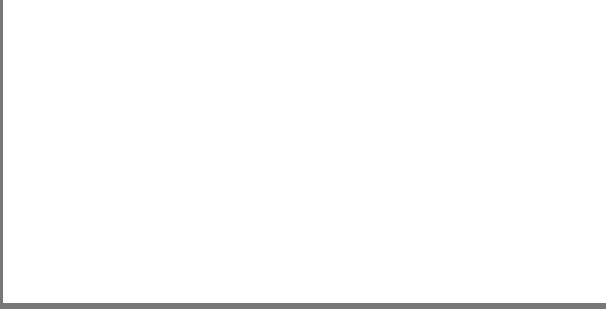

For additional product information  
and services please visit:  
[www.ammann.com](http://www.ammann.com)

