

## TECHNICAL SPECIFICATIONS

### Engine

Engine Model	YANMAR 3TNV80F-SN
Number of Cylinders	3
Max. Torque/Speed	63~67.3/1800±100N·m/rpm
Displacement	1.267L

### Hydraulic system

Max. Main Pump Flow	90L/min
Main Safety Valve Pressure	24MPa

### Main Performance

Bucket Digging Force	27.5kN
Arm Digging Force	14.2kN
Max. Traction Force	25kN
Max. Walking Speed	4.5km/h
Min. Walking Speed	2.5km/h
Rotary Speed	10r/min
Gradeability	30°
Ground Pressure	26.7kPa

### Oil Capacity

Fuel Tank	33L
Hydraulic Tank	31L
Engine Oil	3.4L



### LOVOL HEAVY INDUSTRY GROUP CO.,LTD.

Address: No. 75, Huanghe East Road, Huangdao District, Qingdao City, Shandong Province, China.

Website: [en.wlovol.com](http://en.wlovol.com) E-mail: [lovol\\_overseas@global.lovol.com](mailto:lovol_overseas@global.lovol.com) TEL: +86-532-86907190 Facebook: Cons Lovol

As manufacturer, LOVOL has right to constantly upgrade and improve our products without informing to customers. The pictures in literatures are for reference only, the detailed specifications are subject to real products.

Rated Power **15.2kW/2500rpm**

Operating Weight **2800kg**

Bucket Capacity **0.08 m³**

# FR26F-u

EXCAVATOR



## FLEXIBILITY

**Tailless design** - Turning radius 775mm

**Boom side shift** - Small space corner operation

**Universal adaptation**

Quick matching of various electronic control accessories



## RELIABILITY

**Boom bucket rod assembly explosion-proof valve**

Prevent falling, oil spray

**Load sensitive flow control**

Allocate the appropriate flow according to the demand of the load

**Large working range**

Maximum excavation radius 4887 mm

**Large bucket capacity**

Bucket 0.08m<sup>3</sup>, High working efficiency

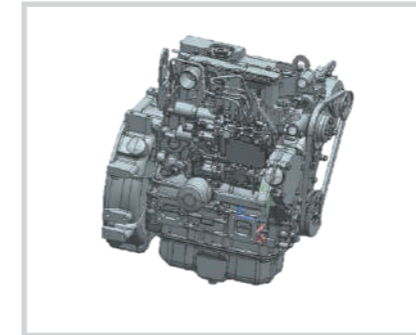
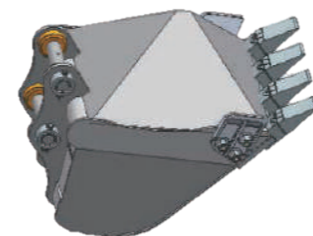

## EFFICIENCY

Yanmar engine, low noise

Load sensitive main pump, low fuel consumption

Load sensitive main valve, distribution of appropriate flow, low fuel consumption

NACHI rotary motor, high reliability of imported products

NACHI Walking motor, high reliability of imported products

The boom bucket rod is equipped with explosion-proof valve to prevent falling and oil spraying, which is safer

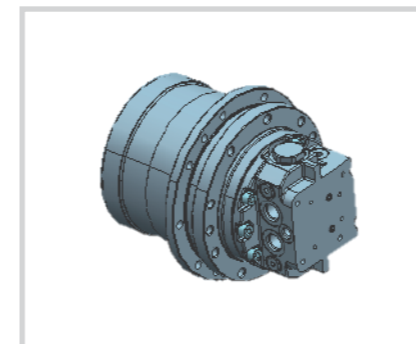

## COMFORT



### Yanmar engine

Low indoor and outdoor noise

### Large radiator area

High heat dissipation performance

### Wide field of view

No cover around the cab

Multi-functional handle to achieve crushing, quick change, tilt quick change, hydraulic shear and single and double direction switching operations

Full touch screen instrument, easy to operate

## INTELLIGENCE



### Multifunctional pilot handle

Electronic control of various accessories

### Full touch screen, one click start

The key switch is easy to operate



## INCREASE YOUR PRODUCTIVITY AND PROFIT WITH LOVOL ATTACHMENTS

You can easily expand the performance of your machine by utilizing any of the variety of LOVOL Attachments. Each LOVOL Attachments is designed to fit the weight and horsepower of LOVOL Excavator for improved performance, safety, and stability.



## TECHNICAL SPECIFICATIONS

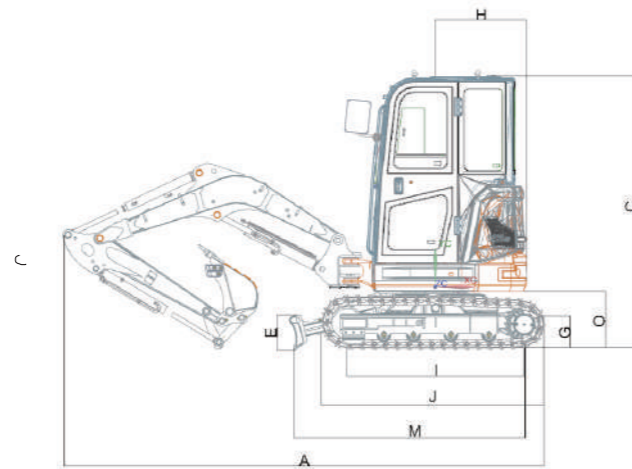
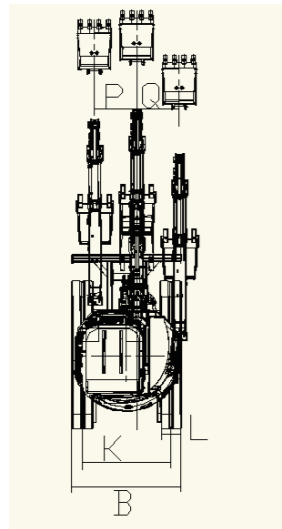

### Working Range

Max. Digging Height	1	4480mm
Max. Dumping Height	2	3098mm
Max. Digging Depth	3	2845mm
Max. Vertical Digging Depth	4	2550mm
Max. Digging Radius	5	4887mm
Max. Ground Digging Radius	6	4768mm

### Dimensions

Shipping Length	A	4230mm
Shipping Width	B	1550mm
Boom Height	C	2425mm
Dozer Blade Height	D	300mm
Min. Ground Clearance	E	300mm
Tail Turning Radius	F	775mm
Length to Center of Rollers	G	1560mm
Track Length	H	1990mm
Track Gauge	I	1250mm
Track Shoe Width	J	300mm
Shipping Ground Length	K	/
Track Plate Height	L	/
Ground Clearance of Counter Weight	M	500mm

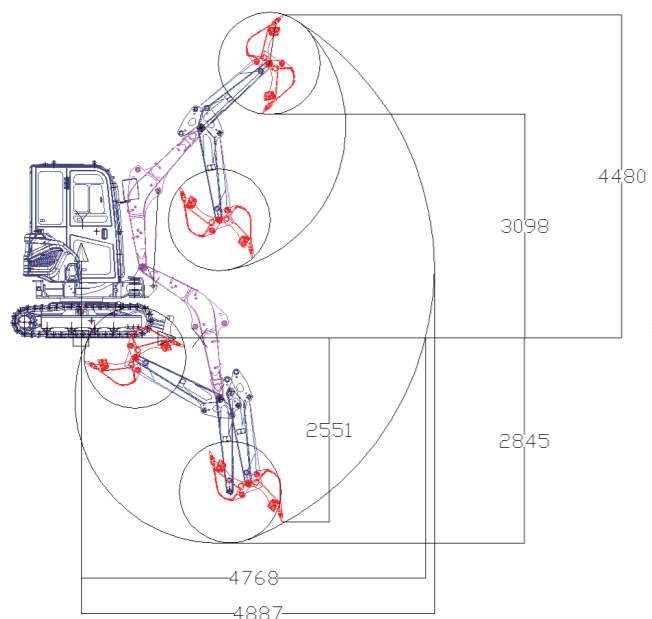

### Other Specifications

Boom Length	2100mm
Arm Length	1300mm
Track Section Number (each side)	41
Track Roller Number	4